

---

**INSTRUCTION MANUAL**

---

**DEWALT**®

---

**DW352/DW359**  
**DW389**

**7 1/4" CIRCULAR SAWS**  
**9 1/4" CIRCULAR SAW**

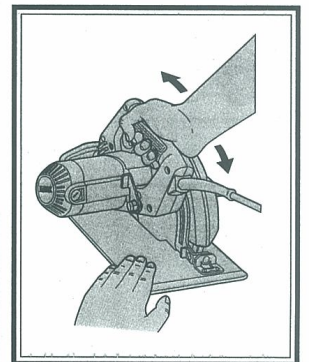
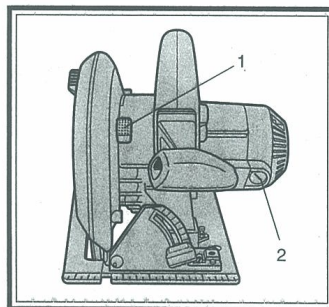
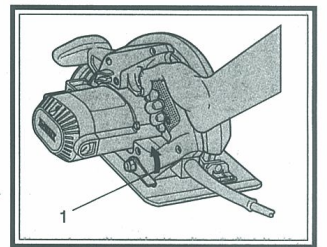
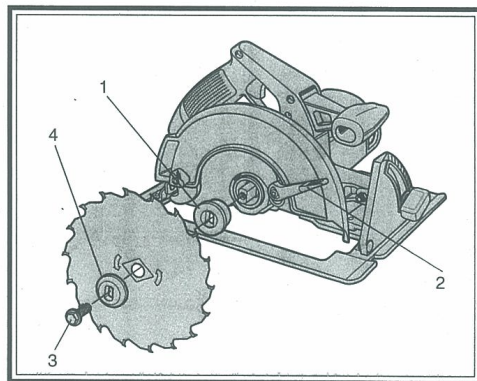

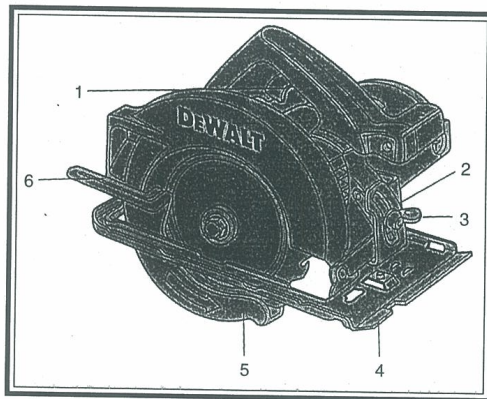

DW352

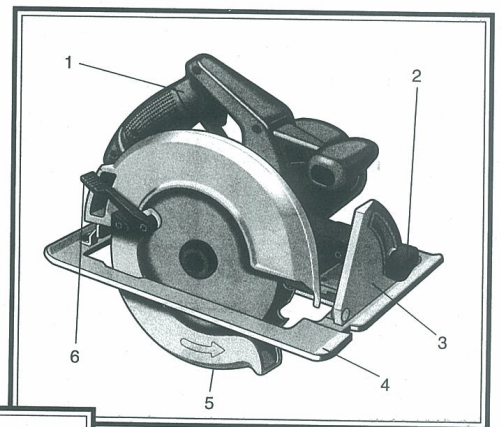

DW359

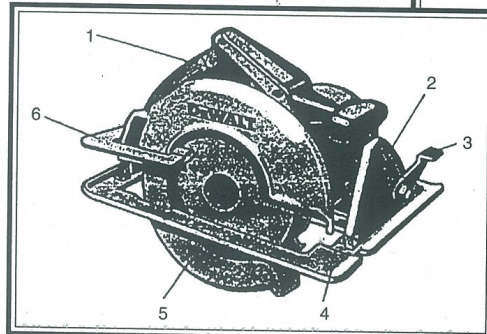

DW389

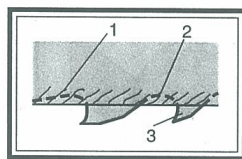

5A

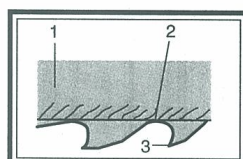

5B

6

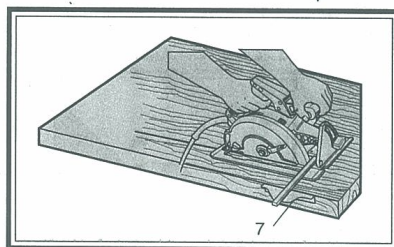
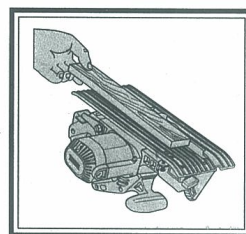

7

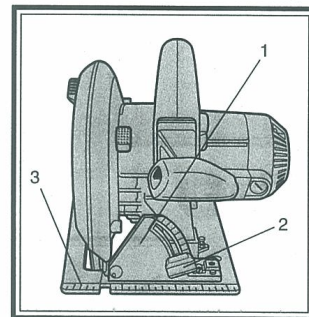

8

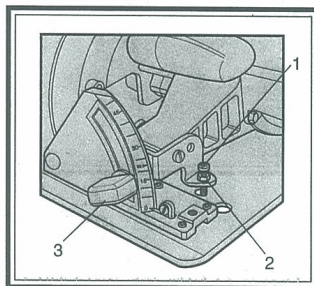

10

9

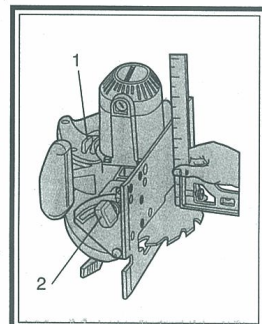

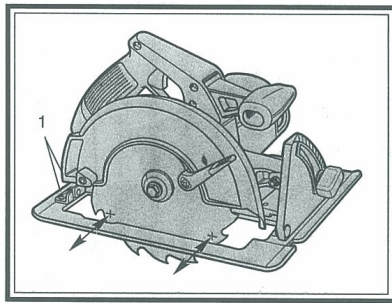

11

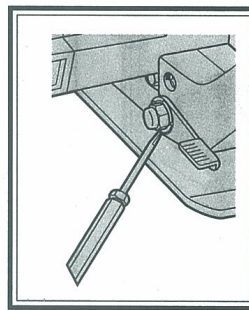

12

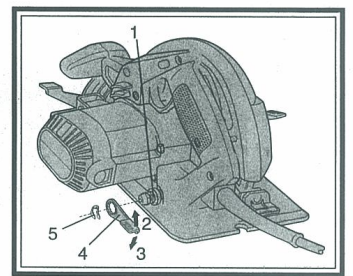

13

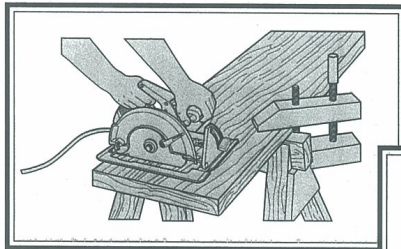

14

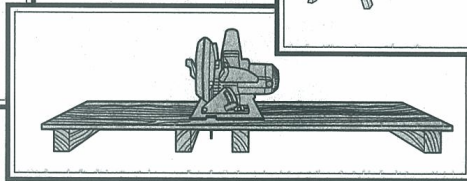
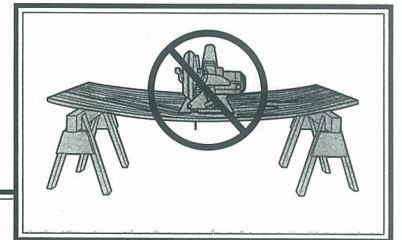

16

15

**Description (DW 352)**

1. Trigger switch
2. Bevel quadrant
3. Quadrant nut
4. Shoe
5. Lower guard
6. Retracting lever

**Description (DW 359)**

1. Trigger switch
2. Quadrant lever
3. Bevel quadrant
4. Shoe
5. Lower guard
6. Retracting lever

**Description (DW 389)**

1. Trigger switch
2. Bevel quadrant
3. Quadrant lever
4. Shoe
5. Lower guard
6. Retracting lever

**Description (FIG. 1)**

1. Inner clamp washer
2. Retracting lever
3. Blade clamping screw
4. Outer clamp washer

**Description (FIG. 2)**

1. Blade lock
2. Brush inspection cap

**Description (FIG. 3)**

1. Tighten
2. Loosen

**Description (FIG. 4)**

1. Depth adjustment lever

**Description (FIG. 5)**

1. Depth adjustment

**Description (FIG. 5A/5B)**

1. Surface of wood
2. Gullet
3. Tip of tooth

**Description (FIG. 6)**

1. Setting depth of cut

**Description (FIG. 7)**

1. Rip fence

**Description (FIG. 8)**

1. Quadrant
2. Quadrant lever or knob
3. Kerf indicator

**Description (FIG. 9)**

1. Cord keeper
2. Quadrant lever or knob

**Description (FIG. 10)**

1. Adjustment screw
2. Hex nut
3. Quadrant lever or knob

**Description (FIG. 11)**

1. Shoe adjustment screws

**Description (FIG. 13)**

1. Lock nut
2. Loosen
3. Tighten
4. Lever
5. Lock ring

**Description (FIG. 14/15)**

1. Correct cutting procedure

### Safety Instructions

When using power tools, always observe the safety regulations applicable in your country to reduce the risk of fire, electric shock and personal injury. Read the following safety instructions before attempting to operate this product. Keep these instructions in a safe place!

#### General

- 1 Keep work area clean.** Cluttered areas and benches can cause accidents.
- 2 Consider work area environment.** Do not expose power tools to high humidity or rain. Keep work area well lit. Do not use power tools in the presence of flammable liquids or gases.
- 3 Guard against electric shock.** Prevent body contact with earthed surfaces (e.g. pipes, radiators, cookers and refrigerators).
- 4 Keep children away.** Do not let children come into contact with the tool or extension cord. Keep all people away from the work area.
- 5 Extension cords for outdoor use.** When the tool is used outdoors, always use extension cords intended for outdoor use and mark accordingly.
- 6 Store idle tools.** When not in use, power tools must be stored in a dry place and locked up securely, out of reach of children.
- 7 Dress properly.** Do not wear loose clothing or jewellery. They can be caught in moving parts. Preferably wear rubber gloves and non-slip footwear when working outdoors. Wear protective hair covering to keep long hair out of the way.
- 8 Wear safety goggles.** Also use a face or dust mask in case the operations produce dust or flying particles.
- 9 Be aware of maximum sound pressure.** Take appropriate measures for the protection of hearing if the sound pressure of 85dB(A) is exceeded.
- 10 Secure workpiece.** Use clamps or a vice to hold the workpiece. It is safer and it frees both hands to operate the tool.
- 11 Do not overreach.** Keep proper footing and balance at all times.
- 12 Avoid unintentional starting.** Do not carry the plugged-in tool with a finger on the switch. Be sure that the switch is released when plugging in.
- 13 Stay alert.** Watch what you are doing. Use common sense. Do not operate the tool when you are tired.
- 14 Disconnect tool.** Shut off power and wait for the tool to come to a complete standstill before leaving it unattended. Unplug the tool when not in use, before servicing or changing accessories.
- 15 Remove adjusting keys and wrenches.** Always check that adjusting keys and wrenches are removed from the tool before operating the tool.
- 16 Use appropriate tool.** Do not force small tools or attachments to do the job of a heavy-duty tool. The tool will do the job better and safer at the rate for which it is intended. The use of any accessories or attachments other than the ones recommended in this instruction manual may induce a risk of personal injury.
- 17 Do not abuse cord.** Never carry the tool by its cord or pull it to disconnect from the socket. Keep the cord away from heat, oil and sharp edges.
- 18 Maintain tools with care.** Keep tools in good condition and clean for better and safer performance. Follow the instructions for maintenance and changing accessories. Inspect tool cords at regular intervals and, if damaged, have them repaired by an authorised DeWALT Repair Agent. Inspect extension cords periodically and replace them if damaged. Keep all controls dry, clean and free from oil and grease.
- 19 Check damaged parts.** Before using the tool, carefully check it for damage to ensure it will operate properly and perform its intended function. Check for misalignment and seizure of moving parts, breakage of parts and any other conditions that may affect its operation. Have damaged guards or other defective parts repaired or replaced as instructed. Do not use the tool if the switch is defective. Have the switch replaced by an authorised DeWALT Repair Centre.
- 20 Have your tool repaired by an authorised DeWALT Repair Centre.** This power tool is in accordance with the relevant safety regulations. To avoid danger, electric appliances must only be repaired by qualified technicians.

### **Additional Safety Instructions for Circular Saws**

- **CAUTION:** When cutting into walls, floors or wherever live electrical wires may be encountered, **DO NOT TOUCH ANY METAL PARTS OF THE TOOL!** Hold the saw only by its plastic insulated handles to prevent electric shock if you cut in the live wire.
- **KEEP GUARDS IN PLACE AND IN WORKING ORDER.** Never wedge or tie lower guard open. Check operation of lower guard before each use. Do not use if lower guard does not close briskly over saw blade. **CAUTION:** If saw is dropped, lower guard may be bent, restricting full return. Do not use saw until it is returned to proper working order.
- **KEEP BLADES CLEAN AND SHARP.** Sharp blades minimize stalling, overload and kickback, and give a cleaner cut.
- **DANGER: KEEP HANDS AWAY FROM CUTTING AREA.** Keep hands away from blades. Do not reach underneath work while blade is rotating. Do not attempt to remove cut material when blade is moving. **CAUTION:** Blades coast after turn off.
- **SUPPORT LARGE PANELS.** Large panels must be supported as shown in figure 16 to minimize the risk of blade pinching and kickback. When cutting operation requires the resting of the saw on the workpiece, the saw shall be rested on the larger portion and the smaller piece cut off.
- **USE RIP FENCE.** Always use a rip fence or straight edge guide when ripping.
- **GUARD AGAINST KICKBACK.** Kickback occurs when the saw stalls rapidly and is driven back towards the operator. Release switch immediately if blade binds or saw stalls. Keep blades sharp. Support large panels as shown in figure 16. Use fence or straight edge guide when ripping. Don't force tool. Stay alert-exercise control. Don't remove saw from work during a cut while the blade is moving.
- **LOWER GUARD.** When necessary for accurate starts or when pocket cutting, raise lower guard with the retracting lever.
- **ADJUSTMENTS.** Before cutting be sure depth and bevel adjustments are tight.
- **USE ONLY CORRECT BLADES IN MOUNTING.** Do not use blades with incorrect size holes. Never use defective or incorrect blade washers or bolts.

- **AVOID CUTTING NAILS.** Inspect for and remove all nails from timber before cutting.

**CAUTION:** Some wood contains preservatives such as copper chromium arsenate (CCA) which can be toxic. When cutting these materials extra care should be taken to avoid inhalation and minimize skin contact.

#### **SAVE THESE INSTRUCTIONS**

### **Motor**

Your DeWalt tool is powered by a DeWalt motor. Be sure your power supply agrees with nameplate marking. Lower voltage can cause loss of power and can result in overheating. All DeWalt tools are factory-tested; if this tool does not operate, check the power supply.

### **Brushes**

#### **DISCONNECT PLUG FROM POWER SUPPLY BEFORE SERVICING**

Inspect carbon brushes regularly by unplugging tool, removing the Brush Inspection Cap and withdrawing the brush assembly. Keep brushes clean and sliding freely in their guides. Always replace a used brush in the same orientation in the holder as it was prior to removal. Carbon brushes have varying symbols stamped into their sides, and if the brush is worn down to the line closest to the spring, they must be replaced. Use only identical DeWalt brushes. Always replace both brushes. Run saw without a blade for 10 minutes to bed new brushes in.

### **Adjustments and Setup**

#### **ATTACHING AND REMOVING BLADES (Note: Fig shown are using model DW359)**

#### **DISCONNECT PLUG FROM POWER SUPPLY.**

To attach the blade, retract lower blade guard and place inner clamp washer and blade on saw spindle with printed side of blade out (teeth at bottom of blade pointing forward) (FIG. 1.) Place outer clamp washer on saw spindle. Thread on blade clamping screw firmly by hand to hold both blade washers in position.

Lightly depress the blade lock (FIG.2) while turning the spindle until the blade stops rotating. Tighten blade clamping screw (clockwise) firmly with the blade wrench (FIG. 3).

**Note:** Model DW352 has a reversible inner flange clamp for use with saw blades having a 5/8" (15.9 mm) or 1" (25.4 mm) diameter arbor hole. If you will be using a blade made by another manufacturer which has an arbor hole larger than 5/8" (15.9 mm) but smaller than 1" (25.4 mm), two spacer washers have been provided with your saw. The two washers, 19 mm and 20 mm diameters have arbor hole diameters of 5/8" (15.9 mm). Select the washer that exactly fits your saws blade.

**NEVER ENGAGE BLADE LOCK WHILE SAW IS RUNNING, OR ENGAGE IN AN EFFORT TO STOP THE TOOL. NEVER TURN SWITCH ON WHEN BLADE LOCK IS ENGAGED. SERIOUS DAMAGE TO YOUR SAW WILL RESULT.**

When removing the blade, first unplug the saw. Engage the blade lock and unscrew the blade clamping screw by turning it counterclockwise with the blade wrench.

#### CUTTING DEPTH ADJUSTMENT

DISCONNECT PLUG FROM POWER SUPPLY.

Hold the saw firmly as shown in Figure 4. Loosen (counter-clockwise) the Depth Adjustment Lever and move shoe to obtain the desired depth of cut, as shown in Figure 5. Make sure the Depth Adjustment Lever has been relightened (clockwise) before operating saw.

For the most efficient cutting action, set the depth adjustment so that about one half of a tooth projects below the surface of the wood to be cut. The height of a whole tooth is the distance from the tip of the tooth to the bottom of the gullet in front of it. Study Figures 5A and 5B to determine what one half tooth means. (5A shows one half tooth projecting below the surface and figure 5B shows a whole tooth projecting below the surface.)

Setting the saw at the proper cutting depth keeps blade friction to a minimum, removes sawdust from between the blade teeth, results in cooler, faster sawing and reduces the chance of kickback.

A method of checking for the correct cutting depth is shown in Figure 6. Lay a piece of the material you plan to cut along the side of the blade, as shown in the figure, and observe how much tooth projects beyond the material.

**NOTE:** When using a non carbide tipped blade, make an exception to the above procedure and allow a full tooth to project below the material, as shown in Figure 5B.

#### BEVEL ANGLE ADJUSTMENT

DISCONNECT THE SAW FROM THE POWER SUPPLY.

On the front of the saw is a bevel angle adjustment mechanism (Figure 8) consisting of a calibrated quadrant and a lever or knob. To set the saw for a bevel cut, Loosen (counter-clockwise). The quadrant lever or knob and tilt shoe to the desired angle by aligning the pointer with the desired angle mark. Relighten lever or knob firmly (clockwise).

#### SHOE ALIGNMENT (FOR DW359 & DW389 ONLY)

Your saw has been set at the factory for accurate vertical cuts (a 90 degree angle between the bottom of the shoe and the blade). The edge of the shoe has also been set parallel to the blade so that it will not bind when using an edge guide. If the saw should ever need adjustment, it may be done as follows:

#### ADJUSTING FOR 90° CUTS (Fig shown are using model DW359)

1. DISCONNECT PLUG FROM POWER SUPPLY.
2. Adjust the saw to 0° bevel.
3. Place saw on blade side (Fig. 9). Retract blade guard.
4. Loosen quadrant lever or knob (Fig. 9). Place a square against the blade and shoe to adjust the 90° setting.
5. Loosen the hex nut and move the adjustment screw so that the shoe will stop at the proper angle as shown in Figure 10. Lock the screw in place by tightening the hex nut.
6. (It may be necessary to adjust the quadrant angle pointer to line up on "0" after shoe has been adjusted.

#### ADJUSTING THE SHOE PARALLEL TO THE BLADE (FOR DW359 & DW389 ONLY)

(Your saw is adjusted at the factory so that the blade and shoe are parallel. If these parts become misaligned, adjust as follows.)

1. DISCONNECT PLUG FROM POWER SUPPLY.
2. Loosen the (1) screws at the adjusting bracket at the rear of the shoe, as shown in Figure 11.
3. Adjust the shoe until it is parallel to the blade by measuring from the edge of the shoe to the blade, front & rear. You can measure from the outside edge of the blade to the shoe as shown in Figure 11 or from the inner edge of the blade to the wider part of the shoe. (Do not measure from the tips of any saw blade teeth.)
4. When shoe is parallel, tighten all screws.

### ADJUSTING DEPTH ADJUSTMENT & QUADRANT LEVERS OR KNOBS (FOR DW359 & DW389 ONLY)

It may be desirable to adjust the Depth Adjustment and Quadrant Adjustment lever or knob. (They will sometimes hit the shoe before tightening or loosening completely.) To adjust either lever, follow the steps below.

1. DISCONNECT PLUG FROM POWER SUPPLY.
2. Using a small screwdriver, pry the lock ring off, as shown in Figure 12.
3. Remove the lever and rotate it in the desired direction about 1/8 revolution. (More or less as necessary.)
4. Reinstall the lever and insert the lock ring with concave side against lever to hold it in place. (Figure 13)

### Operation

#### SWITCH

Pull the trigger switch to turn the motor "ON". Releasing the trigger turns the motor "OFF". Releasing the trigger also automatically actuates the electric brake on units so equipped.

#### WORKPIECE SUPPORT

Figure 14 show proper sawing position. Note that hands are kept away from cutting area, and power cord is positioned clear of the cutting area so that it will not get caught or hung up on the work.

To avoid kickback, DO support board or panel NEAR the cut, (Figure 15). DON'T support board or panel away from the cut (Figure 16).

Be sure saw is up to full speed before blade contacts material to be cut. Starting saw with blade against material to be cut or pushed forward into kerf can result in kickback.

Push the saw forward at a speed which allows the blade to cut without labouring. Hardness and toughness can vary even in the same piece of material, and knotty or damp sections can put a heavy load on the saw. When this happens, push the saw more slowly, but hard enough to keep it working without much decrease in speed.

Forcing the saw can cause rough cuts, inaccuracy, kickback and over-heating of the motor.

Should your cut begin to go off the line, don't try to force it back on. Release the switch and allow blade to come to a complete stop. Then you can

withdraw the saw, sight anew, and start a new cut slightly inside the wrong one. In any event, withdraw the saw if you must shift the cut. Forcing a correction inside the cut can stall the saw and lead to kickback. IF SAW STALLS, RELEASE THE TRIGGER AND BACK THE SAW UNTIL IT IS LOOSE, BE SURE BLADE IS STRAIGHT IN THE CUT AND CLEAR OF THE EDGE BEFORE RESTARTING.

As you finish a cut, release the trigger and allow the blade to stop before lifting the saw from the work. When you have to retract the telescoping guard manually (as is necessary for starting pocket cuts) always use the retracting lever.

**NOTE:** When ripping (cutting with the grain) the use of a rip fence is recommended. (See Figure 7)

#### POCKET CUTTING

DISCONNECT PLUG FROM POWER SUPPLY WHEN MAKING THIS OR ANY OTHER ADJUSTMENT. Adjust saw shoe so blade cuts at desired depth. Tilt saw forward and rest front of the shoe on material to be cut. Using the retracting lever, retract blade guard to an upward position. Lower rear of shoe until blade teeth almost touch cutting line. Now release the blade guard (its contact with the work will keep it in position to open freely as you start the cut). Start the motor and gradually lower the saw until its shoe rests flat on the material to be cut. Advance saw along the cutting line until cut is completed. Release trigger and allow blade to stop completely before withdrawing the blade from the material. When starting each new cut, repeat as above. Never tie the blade guard in a raised position.

#### Kickback

When the saw blade becomes pinched or twisted in the cut, kickback can occur. The saw is thrust rapidly back toward the operator. When the blade is pinched or bound tightly by the kerf closing down, the blade stalls and the motor reaction drives the unit backward. When the blade becomes twisted or misaligned in the cut, the teeth at the back edge of the blade can dig into the top surface of the wood causing the blade to climb out of the kerf and jump back toward the operator.

Kickback is more likely to occur when any of the following conditions exist.

1. IMPROPER WORKPIECE SUPPORT
  - A. Sagging or improper lifting of the cut off piece causing pinching of the blade.

- B. Cutting through material supported at the outer ends only (see Figure 16). As the material weakens it sags, closing down the kerf and pinching the blade.
  - C. Cutting off a cantilevered or overhanging piece of material from the bottom up in a vertical direction. The falling cut off piece can pinch the blade.
  - D. Cutting off long narrow strips (as in ripping). The cut off strip can sag or twist closing the kerf and pinching the blade.
  - E. Snagging the lower guard on a surface below the material being cut momentarily reducing operator control. The saw can lift partially out of the cut increasing the chance of blade twist.
2. IMPROPER DEPTH OF CUT SETTING ON SAW
- Using the saw with an excessive depth of cut setting increases loading on the unit and susceptibility to twisting of the blade in the kerf. It also increases the surface area of the blade available for pinching under conditions of kerf close down.
3. BLADE TWISTING (MISALIGNMENT IN CUT)
- A. Pushing harder to cut through a knot, a nail, or a hard grain area can cause the blade to twist.
  - B. Trying to turn the saw in the cut (trying to get back on the marked line) can cause blade twist.
  - C. Extended reach or operating saw with poor body control (out of balance), can result in twisting the blade.
  - D. Changing hand grip or body position while cutting can result in blade twist.
  - E. Backing unit up to clear blade can lead to twist if not done carefully.
4. LIFTING THE SAW WHEN MAKING BEVEL CUTS
- Bevel cuts require special operator attention to proper cutting techniques- especially guidance of the saw. Both blade angle to the shoe and greater blade surface in the material increase the chance for binding and misalignment (twist) to occur.
5. RESTARTING A CUT WITH THE BLADE TEETH JAMMED AGAINST THE MATERIAL
- The saw should be brought up to full operating speed before starting a cut or restarting a cut after the unit has been stopped with the blade in the kerf. Failure to do so can cause stalling and kickback.
- Any other conditions which could result in pinching, binding, twisting, or misalignment of the blade could cause kickback.

### **Blades**

A dull blade will cause slow, inefficient cutting, overload on the saw motor, excessive splintering and increase the possibility of kickback. It is a good practice to keep extra blades on hand so that sharp blades are available while the dull ones are being sharpened. Hardened gum on the blade will slowdown the cutting, the gum can be removed with kerosene, Turpentine, or even oven cleaner.

### **DeWALT After-Sales Service**

All DeWALT power tools are thoroughly tested before leaving the factory. However, if the power tool needs repair, please contact your dealer or take it to your nearest DeWALT Service Centre.

### **Guarantee**

#### **Full One Year Warranty**

DeWALT heavy duty industrial tools are warranted for one year from date of purchase. We will repair, without charge, any defects due to faulty materials or workmanship. Arrangements have been made with the Industrial Tool Division of Black & Decker to provide warranty repairs for DeWALT tools. Please return the complete unit, transportation prepaid, to any DeWALT Service Centre, Black & Decker Service Centre or any authorised service station. This warranty does not apply to:

- Accessories
- Damage caused where repairs have been made or attempted by others
- Damage due to misuse, neglect, wear and tear, alteration or modification.

#### **Free One Year Service Contract**

In addition to a full one year warranty, every DeWALT tool is backed with a Free One Year Service Contract. We will provide free labour on all repair and preventative maintenance during the first year after purchase. Proof of purchase date is required.

---

**30 Day No Risk Satisfaction Guarantee**

If you are not completely satisfied with the performance of your DeWALT heavy duty industrial tool, simply return it to the participating seller within 30 days. Proof of purchase date is required.

***Unwanted Tools And The Environment***

Take your old tool to an authorised DeWALT Repair Agent where it will be disposed off in an environmentally safe way.

Note: This instruction manual is applicable for the following sub-codes – XE, – A9, – TW

DeWALT Industrial Tool Company

Form No. 154482 (JUL96-CD-1) Copyright © 1996

Part No. 154482-00